

## KEEPING THE HI-0201 SWITCH CLOSED WHEN REMOVING THE V+ SUPPLY

Authors: Larry Ashline, Bill Satterfield, Dave Jarman

In certain applications it is desirable for a switch to remain in a particular state (open or closed) when either one or both of the power supplies are removed. This application note will discuss keeping the HI-0201 switch closed when the positive power supply is removed.

The test circuit of Figure 1 shows that the V+ supply is switched from +15V to ground. The address line of the switch being tested is grounded (logic low), the V<sub>REF</sub> pin is floating, and the input to the switch is at -14V. Several HI-0201 units were tested using the circuit shown in Figure 1. The results indicated the state of the switch to be unpredictable - some switches would remain closed while other switches would open when the V+ supply was switched from +15V to ground. Yet the state was predictable on any given device, i.e. if a particular switch opened, it opened every time. In fact, all four switches on a particular HI-0201 unit behaved the same. Figure 2 shows the switching waveforms.

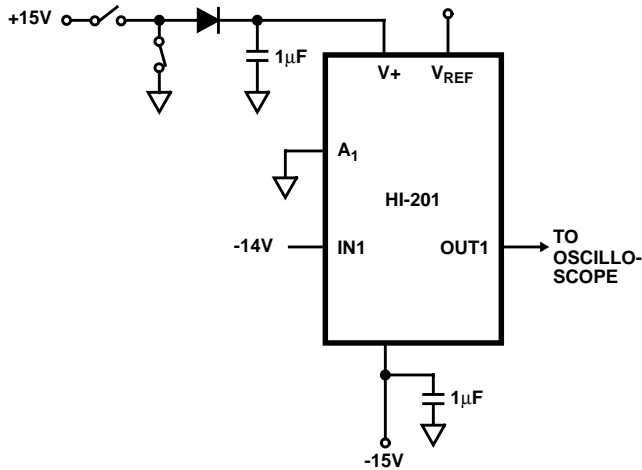

FIGURE 1. TEST CIRCUIT

Circuit analysis indicated that any one of three external circuit modifications could be made to ensure that a switch would remain closed when V+ is removed:

1. Replace the 1µF capacitor on the V+ supply with a 0.01µF capacitor.
2. Add a 0.1µF capacitor from V<sub>REF</sub> to ground.
3. Lower the V<sub>IL</sub> applied to the digital input buffer pins to -0.8V (bringing the logic low level down below ground could cause latch-up problems on other components and is not recommended during normal operation of the HI-0201).

(Please note that the capacitor values mentioned in (1) and (2) above may need to be modified slightly for different applications and circuit boards.)

In summary, the typical behavior of the HI-0201 switch when removing the V+ supply is unpredictable. However, either of the three external circuit modifications listed above will ensure the switches remain closed after the V+ supply is removed.

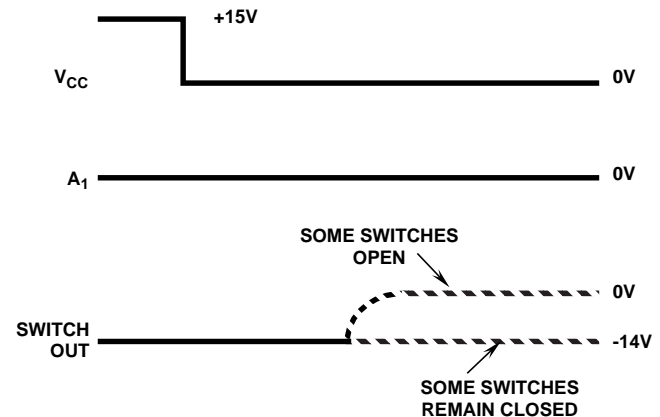

FIGURE 2. SWITCH WAVEFORMS

All Intersil semiconductor products are manufactured, assembled and tested under ISO9000 quality systems certification.

*Intersil products are sold by description only. Intersil Corporation reserves the right to make changes in circuit design and/or specifications at any time without notice. Accordingly, the reader is cautioned to verify that data sheets are current before placing orders. Information furnished by Intersil is believed to be accurate and reliable. However, no responsibility is assumed by Intersil or its subsidiaries for its use; nor for any infringements of patents or other rights of third parties which may result from its use. No license is granted by implication or otherwise under any patent or patent rights of Intersil or its subsidiaries.*

For information regarding Intersil Corporation and its products, see web site <http://www.intersil.com>